

1- Ubique el cuerpo de la válvula con el aviso UP en la parte superior.

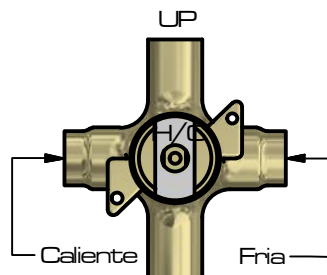

2- Realice la conexión de la tubería de la válvula.

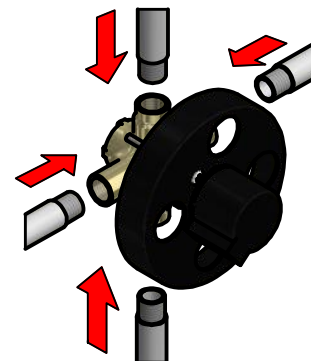

3- Finalizado el enchape retire el protector.

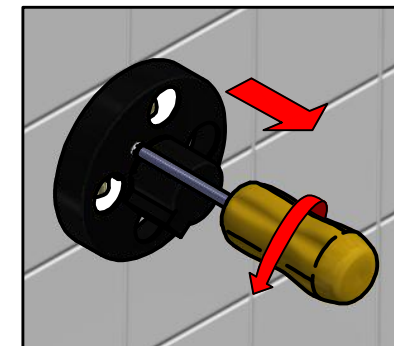

4- Deslice el escudo y ajuste con los tornillos.

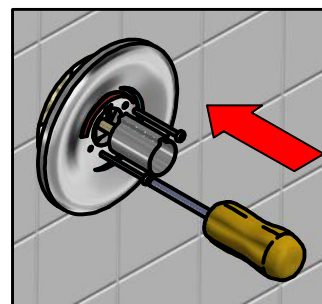

5- Introduzca las piezas como lo ilustra la imagen.

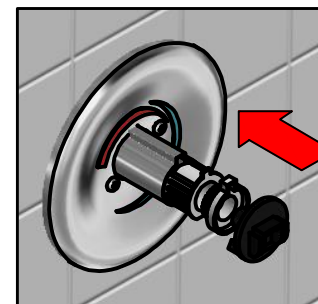

6- Asegure el adaptador.



7- Introduzca la manija.



8- Rosque el prisionero. "No incluye bristol"

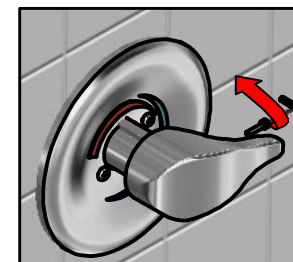

Ensamble Finalizado

